



SUMP & SEWAGE UTILITY PUMPS

Water Systems

Sump & Sewage

Lawn & Sprinkler

Electric Motor
Driven

Engine Driven

Frame Mount

Hand Pumps

Irrigation &
Industrial

UP16M SERIES SUBMERSIBLE UTILITY PUMP



SOLIDS HANDLING CAPABILITY - 1/8"

MOTOR - 1/6 HP, 115 volt, thermal overload protected. 2.1 full load amps. 10 foot power cord. Stainless steel heat treated shaft. Continuous duty "oil free" motor. Permanently lubricated lip seal. CSA approved.

PUMP CASING - Corrosion resistant aluminum for superior heat dissipation. 3/4" NPT discharge.

IMPELLER - Constructed of durable glass reinforced thermoplastic.

GARDEN HOSE ADAPTER - For convenient hook up.

BOTTOM SUCTION DESIGN - Bottom suction design allows pumping to within 1/4" of the surface. Built-in suction strainer to eliminate internal damage from possible debris. Removable filter screen for easy cleaning.

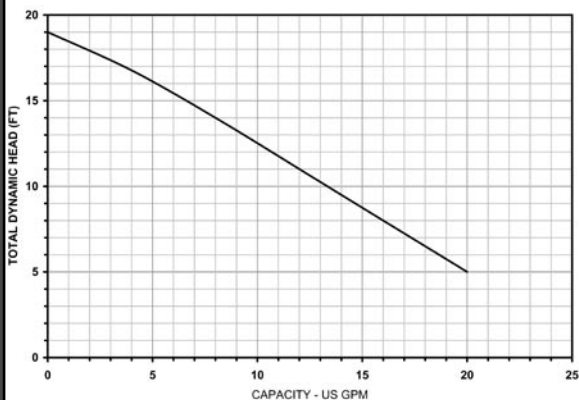

Performance Chart					
Model No.	Total Head in Feet				Shut-Off Head (ft.)
	5	10	15	17	
Capacities in U.S. GPM					
UP16M	20	14	7	4	19

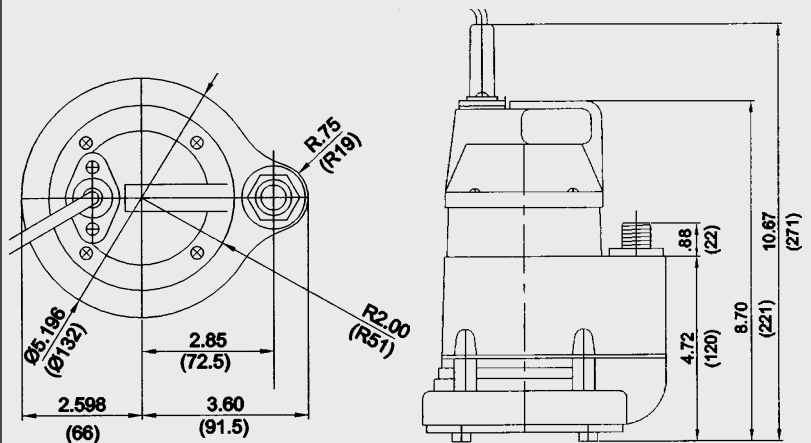

Submersible Utility Pump - 3/4" Discharge

Model No.	Order No.	HP	Ship Wt. (lbs.)	Description
UP16M	620137	1/6	3	Submersible utility pump with garden hose adapter.