



SUMP & SEWAGE SUMP PUMPS

SP33 SERIES SUBMERSIBLE SUMP PUMP

SOLIDS HANDLING CAPABILITY - 1/4"

MOTOR - 1/3 HP, 115 volt, thermal overload protected, CSA approved. 3.5 full load amps. Continuous duty "oil free" motor. Stainless steel motor housing improves heat dissipation for longer motor life. Complete with a 10 foot power cord. Stainless steel heat treated shaft. Permanently lubricated lip seal.

PUMP CASING - Fully constructed of durable reinforced thermoplastic for excellent corrosion resistance. 1 1/4" NPT discharge for ease of installation.

IMPELLER - Non clogging design constructed of durable reinforced thermoplastic.

SWITCH - Automatic, mercury free, mechanical float switch. Also available in manual operation.

BOTTOM SUCTION DESIGN - Built-in suction strainer to eliminate internal damage from possible debris. Removable filter screen for easy cleaning.



SP33A

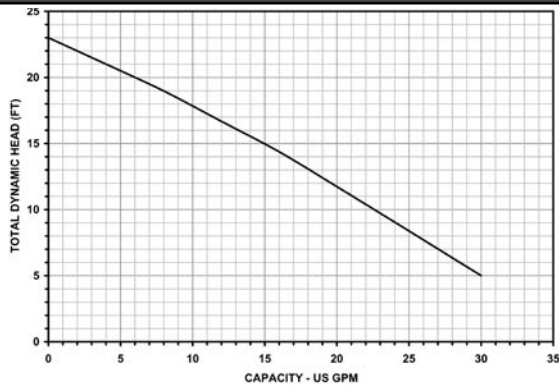

Performance Chart

Model No.	Total Head in Feet				Shut-Off Head (ft.)
	5	10	15	20	
Capacities in U.S. GPM					
SP33	30	23	16	5	23

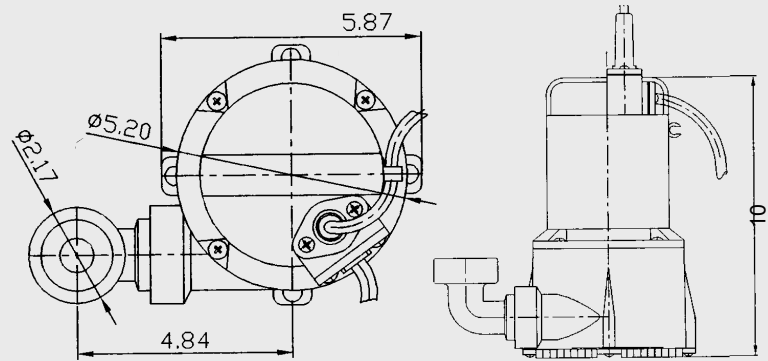

Submersible Sump Pump - 1 1/4" Discharge

Model No.	Order No.	HP	Ship Wt. (lbs.)	Description
SP33A	620135	1/3	10	Submersible sump pump with automatic float switch.
SP33M	620126	1/3	9	Submersible sump pump, manual with 10 ft. cord.

Water Systems

Sump & Sewage

Lawn & Sprinkler

Electric Motor Driven

Engine Driven

Frame Mount

Hand Pumps

Irrigation & Industrial