

# SUMP & SEWAGE SUMP PUMPS



## SP25A SERIES SUBMERSIBLE SUMP PUMP

### SOLIDS HANDLING CAPABILITY - 1/8"

**MOTOR** - 1/4 HP, 115 volt, thermal overload protected. 3.2 full load amps. 10 foot power cord. Stainless steel heat treated shaft. Continuous duty "oil free" motor. Permanently lubricated lip seal. CSA approved.

**PUMP CASING** - Corrosion resistant aluminum for superior heat dissipation. 1-1/4" NPT discharge.

**IMPELLER** - Constructed of durable glass reinforced thermoplastic.

**SWITCH** - Automatic, mercury free, mechanical float switch.

**BOTTOM SUCTION DESIGN** - Bottom suction design allows pumping to within 1/4" of the surface. Built-in suction strainer to eliminate internal damage from possible debris. Removable filter screen for easy cleaning.

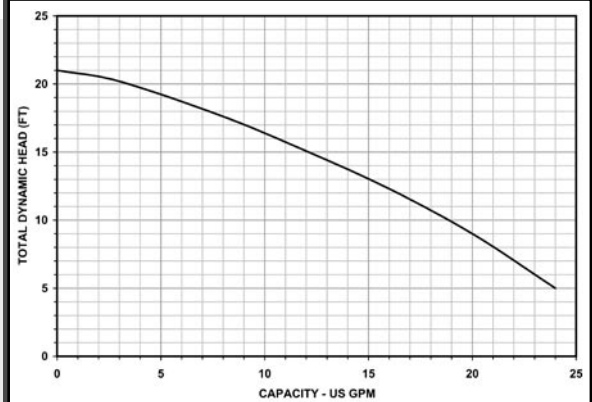
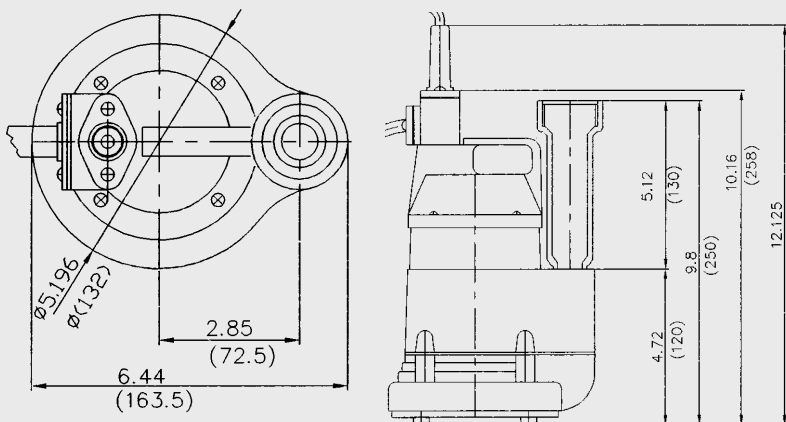

Model No.	Total Head in Feet				Shut-Off Head (ft.)
	5	10	15	20	
	Capacities in U.S. GPM				
SP25A	24	19	12	5	21

### Submersible Sump Pump - 1 1/4" Discharge

Model No.	Order No.	HP	Ship Wt. (lbs.)	Description
SP25A	620136	1/4	8.5	Submersible sump pump.

Water Systems

Sump & Sewage

Lawn & Sprinkler

Electric Motor Driven

Engine Driven

Frame Mount

Hand Pumps

Irrigation & Industrial