

OWNER'S MANUAL

NSGF Series Gasoline Engine Powered Self Priming Pumps



SAFETY WARNINGS



BEFORE OPERATING OR INSTALLING THIS PUMP, READ THIS MANUAL AND FOLLOW ALL SAFETY RULES AND OPERATING INSTRUCTIONS.

SAFETY CAREFULLY READ THESE SAFETY MESSAGES IN THIS MANUAL AND ON PUMP.

- CAUTION**
- **DO NOT OPERATE THIS PUMP DRY!**
 - Review instructions before operating.

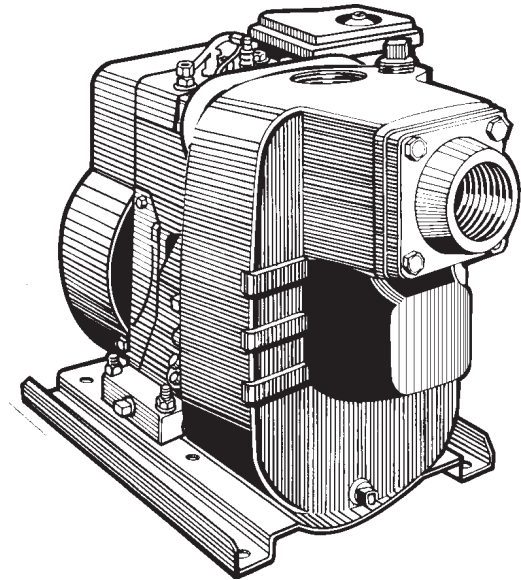

APPLICATION

These high pressure, self priming pumps are ideal for irrigation, sprinkler, fire fighting and general purpose applications, where a suction lift of less than 25' (7.6m) is required.

PERFORMANCE

Model	Flow in US GPM at total head in feet							Flow in L/min at total head in metres					
	25	50	75	100	125	150	175	10	20	30	40	50	60
NSGF3	82	74	60	50	32			305	250	195			
NSGF5	132	118	102	85	65	38		485	410	325	225		
NSGF8	160	159	156	138	118	97	72	605	595	520	430	320	165

INSTALLATION

PUMP LOCATION: The pump should be installed in a clean, dry and ventilated location which provides adequate drainage and room for servicing and protection from freezing temperatures. It should be bolted down evenly on a good foundation, preferably concrete, to prevent the development of unnecessary stress. Locating the pump as close as possible to the source of water supply reduces the friction losses in the suction pipe and provides for maximum capacities.

SUCTION PIPE: It is recommended that only new clean pipe or hose be used and the size be the same as that of the pump suction tapping. If the pump is installed any appreciable distance away from the source of water supply, the suction pipe

should be increased by one size. The suction pipe must always slope upwards from the water source to the pump to avoid air pockets in the line. In cases where the pump has to be reprimed often and it is not necessary that a lot of water be delivered, it is advisable to use a 90° or 45° elbow on the suction line. This enables the pump to prime sooner and also prevents kinking of the hose. In cases where a maximum volume of water is required over a prolonged period of time, the suction line should be led almost horizontally to the pump. Non-toxic thread compound should be used on all pipe joints and connections should be thoroughly tightened. A strainer should be connected to the bottom end of the suction pipe and it should be well submerged at all times.

OPERATION

⚠ WARNING: DO NOT RUN THE PUMP BEFORE PRIMING IT, SINCE THE SEAL AND IMPELLER COULD BE PERMANENTLY DAMAGED.

a) ENGINE: Check the engine manual supplied with the pump for instructions on engine preparation. In particular the unit is shipped without oil which must be added before starting the engine.

b) PRIMING THE PUMP: A priming plug is provided in the top of the casing to fill the pump with water. Once filled and the priming plug replaced, the pump will prime. The priming time depends upon the vertical and horizontal distance between the pump and the water level. The pump should prime itself time after time as long as the built-in check valve functions.

⚠ CAUTION: DO NOT run the pump before filling the pump case with liquid, as it may damage the seal.

c) PRIMING UNDER PRESSURE: Should it be necessary to prime under pressure, place a check valve on the discharge line of the pump and a pet cock or a ball type air bleeder in place of the priming plug, or an air bleed line with a gate valve connected to the discharge line. It will then be possible for the liquid to remain in the discharge pipe and allow the pump to bleed off the remaining air, thereby facilitating priming.

d) STARTING THE PUMP: Never operate the pump dry as this may damage the seal. If an exceptionally long suction line is used, the water in the pump casing may become overheated or vapour locked. Should this occur, replace the water in the casing with cold water and continue priming.

e) DRAINING: Should the pump be subject to freezing temperatures, it will be necessary to drain the pump completely. To drain, remove the drain plug located at the bottom of the front face of the pump casing and the priming plug and make sure that the drain hole is not restricted. After all the water has been drained, operating the pump for a few seconds will ensure that the impeller is devoid of water (make sure that the suction line is also devoid of water).

f) STORAGE OF PUMP: Drain liquid from pump to prevent freezing. It is recommended that a good rust inhibitor be put in the liquid end to prevent excessive corrosion. Be sure motor is kept dry and covered. When restoring the use of the pump, replace all plugs and make sure all connections are tightly sealed. After a complete check is made, make the initial prime according to directions under the section, Priming the Pump.

MAINTENANCE

- a) Engine: Check engine oil level at regular intervals. For additional information refer to the engine instructional manual.
- b) For periodic maintenance the following procedures should be followed:

DISASSEMBLY: Refer to diagram - Note: Not all pumps are exactly as illustrated.

- 1) Remove bolts and remove casing.
- 2) Remove the diffuser (2) and seal ring (12) if they did not come off with the casing.
- 3) Unscrew the impeller (3) (RH thread turn CCW).
- 4) Slide the sleeve (22) and seal (11) off the engine shaft.
- 5) Remove the bolts (24) and remove the adaptor (4) from the engine. Take care not to damage the seal seat.
- 6) Remove the seal seat by pressing out from the rear.

REASSEMBLY: Thoroughly clean all components first.

- 1) Check that the rubber flinger (10) is in position on the engine shaft.
- 2) Lightly oil the rubber cup of the seal seat and press into the adaptor.
- 3) Bolt the adaptor to the engine. On models NSGF3 and NSGF5 with internal bolts (as shown) ensure that the seal washers (33) are in good condition replace if necessary, otherwise leakage may occur.
- 4) Lightly oil the sleeve (22) and slip the rotating part of the seal (11) onto the sleeve and place onto the engine shaft. Ensure that the seal face is oriented towards the seal seat.
- 5) Thread the impeller onto the shaft (RH thread-CW)
- 6) Check the gaskets (16) and replace if necessary.
- 7) Place the diffuser (2) into position on the adaptor and check the condition of the sealing ring (12) replace if necessary.
- 8) Slide the casing over the diffuser and bolt into position.

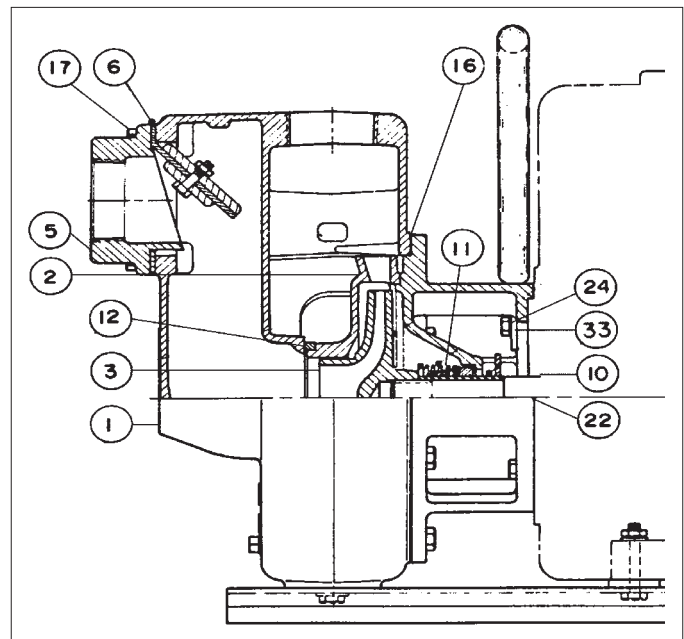

TROUBLESHOOTING GUIDE

TROUBLES AND CAUSE	REMEDY
<p>Failure to Pump:</p> <ol style="list-style-type: none"> 1. Pump not properly primed. 2. Speed too low. 3. Total head more than for which pump was intended. 4. Suction lift is too great. 	<ol style="list-style-type: none"> 1. Make sure pump casing and suction line are full of water. See priming instructions. 2.  WARNING - ELECTRICAL PRECAUTIONS All wiring, electrical connections and system grounding must comply with the National Electrical Code (NEC) and with any local codes and ordinances. Employ a licensed electrician. Check voltage at motor terminals and at meter when pump is operating. If low, refer to wiring instructions or check with your power company. Check loose connections. 3. A pump designed for higher head needed. 4. Locate pump closer to source of water. Make sure suction piping is large enough.
<p>Reduced Capacity and/or Head:</p> <ol style="list-style-type: none"> 1. Air pockets or leaks in suction line. 2. Clogged impeller. 3. Strainer too small or clogged. 4. Insufficient submergence of suction line. 5. Excessive suction lift. 6. Total head more than that for which the pump was intended. 7. Excessively worn impeller. 	<ol style="list-style-type: none"> 1. Check suction piping. 2. Remove and clean. 3. Use larger strainer or clean. 4. Add lengths of suction pipe to keep submerged end well below the water surface. 5. If caused by suction pipe friction, enlarge piping. Otherwise, move pump closer to water level. 6. A pump designed for higher head is needed. 7. Order replacement parts using Repair Parts List.
<p>Pump Loses Prime:</p> <ol style="list-style-type: none"> 1. Air leaks in suction line. 2. Excessive lift and operating too near shut-off point. 3. Water level drops while pumping, uncovering suction piping. 	<ol style="list-style-type: none"> 1. Check suction piping. 2. Move pump nearer water level. 3. Check water supply. Add length of pipe to suction to keep submerged end under water.
<p>Mechanical Troubles and Noise:</p> <ol style="list-style-type: none"> 1. Bent shaft and/or damaged bearings. 2. Suction and/or discharge piping not properly supported and anchored. 	<ol style="list-style-type: none"> 1. Take motor to authorized motor repair shop. 2. See that all piping is supported to relieve strain on pump assembly.

MONARCH INDUSTRIES
51 Burmac Road, P.O. Box 429
Winnipeg, Manitoba, Canada
R3C 3E4

www.monarchindustries.com

LIMITED MONARCH INDUSTRIES WARRANTY

For one year from date of purchase, Monarch Industries will replace or repair for the original purchaser, free of charge, any part or parts, found upon examination by any Monarch Industries Authorized Service Depot or by the Monarch factory, to be defective in material or workmanship or both. Equipment and accessories not manufactured by Monarch Industries are warranted only to the extent of the original manufacturer's warranty. All transportation charges on parts submitted for replacement or repair under this warranty must be borne by the purchaser. For warranty service see your nearest Monarch Industries Authorized Service Depot. THERE IS NO OTHER EXPRESS WARRANTY. IMPLIED WARRANTIES INCLUDING THOSE OF MERCHANTABILITY AND FITNESS FOR A PARTICULAR PURPOSE ARE LIMITED TO ONE YEAR FROM PURCHASE AND TO THE EXTENT PERMITTED BY LAW. LIABILITY FOR CONSEQUENTIAL DAMAGES UNDER ANY AND ALL WARRANTIES ARE EXCLUDED TO THE EXTENT EXCLUSION IS PERMITTED BY LAW.

This warranty is an addition to any statutory warranty.

MONARCH INDUSTRIES

PRINTED
IN
CANADA