

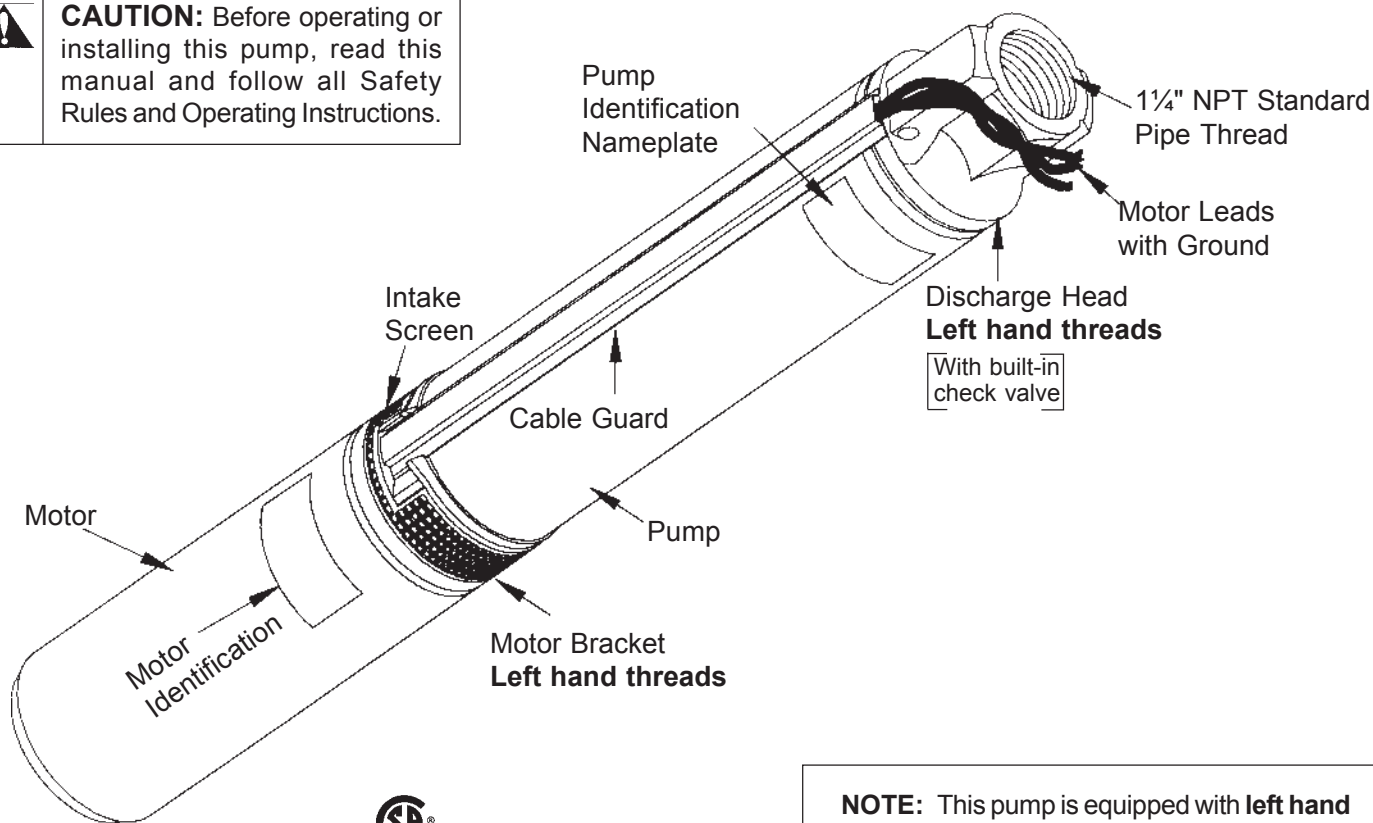

INSTALLATION AND OPERATING INSTRUCTIONS FOR TWO & THREE WIRE 4" DEEP WELL PUMPS.



CAUTION: Before operating or installing this pump, read this manual and follow all Safety Rules and Operating Instructions.



NRTL/C
CSA 108
UL 778

NOTE: This pump is equipped with **left hand threads on the discharge head and the motor bracket housing.** Internal pipe threads in the discharge head are 1-1/4" standard NPT.

INSPECT THE EQUIPMENT

Examine the pump when received to assure there has been no damage in shipping. Should there be any damage evident, report it immediately to the dealer from whom the pump was purchased. Please check the pump package to see that it includes the pump and motor (if your pump purchase includes a motor). Thermoplastic and stainless steel units include a built-in check valve in the discharge head. **A three wire plus a GROUND, single-phase pump REQUIRES a control box** which may be purchased separately if the pump model you have purchased does not include one. The control box must be matched to the pump motor. Make certain that your available voltage corresponds to the voltage required for your motor. Use only Franklin control boxes on Franklin motors. **Two wire plus GROUND pump/motor assemblies DO NOT require a control box.**

Please be sure to fill in the Installation Record on the following page. The information will be necessary should your system require servicing.

INSTALLATION RECORD

For future reference keep an accurate record of your installation. Be sure to accurately record the installation data in the area provided below. **In the package containing the owner's manual a second nameplate is furnished for identification purposes. This nameplate is to be affixed on to the control box, circuit breaker or fused disconnect switch.**

| | |
|---|--|
| Purchased from _____ Pump Model No. _____ Pump Serial No. _____ Date of Installation _____ Discharge Pipe Size (in/mm) _____ Inside Dia. of Well (in/mm) _____ Well Depth (ft/m) _____ Water Depth (ft/m) _____ Pump Depth (ft/m) _____ Well Capacity (US GPM/LPM) _____ | Draw Down Water Level (ft/m) _____ Wire Size (from pump to control box) Gauge _____ Wire Size (from power source to control box) Gauge _____ Distance Between the Well and the House (ft/m) _____ Motor Spec. HP _____ PH _____ Volts _____ Amps _____ Motor Model No. _____ No. of Wires _____ <small>(INCL. GROUND)</small> Control Box Spec. _____ Volts _____ HP _____ Control Box Model No. _____ Power Supply - HZ _____ Volts _____ PH _____ Pressure Switch (PSI) Cutin _____ Cutout _____ |
|---|--|

TABLE OF CONTENTS

| | |
|--|-----------|
| Installation Record | 2 |
| Safety Instructions | 3 |
| Assembly | 3 |
| Tools Required For Assembly | 3 |
| Installation | 4 |
| Before You Install Your Pump - Read these instructions thoroughly! | 4 |
| Installing Your Pump | 5 |
| Drilled Well Installation | 5 |
| Installing the Control Center | 7 |
| Lake or Large Diameter Well Installation | 7 |
| Installations Diagrams | 9 |
| Electrical Connections | 10 |
| Maintenance | 10 |
| Trouble Shooting | 11 |

Congratulations! You are now the owner of a quality MONARCH Submersible Well Pump. The product that you have purchased has been manufactured in Canada using the latest design techniques, materials, and quality workmanship. We have designed this owner's manual to help you get the best use from your new pump. Read these instructions carefully and keep them handy for your future reference.

SAFETY INSTRUCTIONS

WARNING – General Precautions

- Review all the instructions before operating. Failure to follow these instructions could cause bodily injury and/or property damage.
- Though this pump is warranted to handle abrasives, pumping sand continuously shortens the life of the pump and motor and adversely affects their performance. To prevent the above from occurring, the pump & motor should be installed in fully developed wells having the proper well screening to prevent the pumping of abrasives.
- The pump and motor are water cooled and lubricated, and should be sized & used in a well that will provide adequate capacity to prevent running dry. The pump is designed to run dry for intermittent periods, **but the motor is not.**
- The pump, piping and system must be protected against freezing temperatures.
- Wear gloves & eye protection during assembly and installation as precautionary safety measures.
- Never use in swimming pools or pool areas.**

WARNING – Electrical Precautions

All wiring, electrical connections and system grounding must comply with the National Electrical Code (NEC) and with any local codes and ordinances. Employ a licensed electrician.

- A ground fault interrupter (GFI) protected circuit is recommended for use with any electrical device operating near water.
- Have a qualified electrician provide electrical power to the motor. For cable sizes see Table 1.
- Make sure the line voltage, frequency of the electrical current supply match the specifications printed on the motor.
- Be sure leads and ground wires are properly water proofed and securely connected.
- Ensure the motor is properly grounded.
- Always disconnect the power before servicing.
- Never test a pump or use outside a well without proper electrical grounding of the system.

Table 1 - (American) Cable selection

Based on a 5% Voltage drop

(Service entrance to motor - Maximum length in feet)

CAUTION: Use of smaller than recommended cable sizes voids motor warranty!

Two or three wire cable, 60 HZ

| Motor | | (AWG) Copper Wire Size | | | | | | | |
|-------|-------|------------------------|-----|------|------|------|------|------|------|
| HP | Volts | 14 | 12 | 10 | 8 | 6 | 4 | 3 | 2 |
| 1/3 | 115 | 130 | 210 | 340 | 540 | 840 | 1300 | 1610 | 1960 |
| | 230 | 550 | 880 | 1390 | 2190 | 3400 | 5250 | 6520 | 7960 |
| 1/2 | 115 | 100 | 160 | 250 | 390 | 620 | 960 | 1190 | 1460 |
| | 230 | 400 | 650 | 1020 | 1610 | 2510 | 3880 | 4810 | 5880 |
| 3/4 | 230 | 300 | 480 | 760 | 1200 | 1870 | 2890 | 3580 | 4370 |
| 1 | 230 | 250 | 400 | 630 | 990 | 1540 | 2380 | 2960 | 3610 |
| 1 1/2 | 230 | 190 | 310 | 480 | 770 | 1200 | 1870 | 2320 | 2850 |
| 2 | 230 | 150 | 250 | 390 | 620 | 970 | 1530 | 1910 | 2360 |
| 3 | 230 | 120 | 190 | 300 | 470 | 750 | 1190 | 1490 | 1850 |
| 5 | 230 | 0 | 0 | 180 | 280 | 450 | 710 | 890 | 1110 |
| 7 1/2 | 230 | 0 | 0 | 0 | 200 | 310 | 490 | 610 | 750 |

1ft = .3048 meters

Table 1 - (Canadian) Cable selection

Based on a 3% Voltage drop

(Service entrance to motor - Maximum length in feet)

CAUTION: Use of smaller than recommended cable sizes voids motor warranty!

Two or three wire cable, 60 HZ

| Motor | | (AWG) Copper Wire Size | | | | | | | |
|-------|-------|------------------------|-----|-----|------|------|------|------|------|
| HP | Volts | 14 | 12 | 10 | 8 | 6 | 4 | 3 | 2 |
| 1/3 | 115 | 75 | 125 | 205 | 325 | 505 | 780 | 965 | 1175 |
| | 230 | 330 | 528 | 834 | 1314 | 2040 | 3150 | 3912 | 4775 |
| 1/2 | 115 | 60 | 95 | 150 | 235 | 370 | 575 | 715 | 875 |
| | 230 | 240 | 390 | 610 | 965 | 1505 | 2325 | 2885 | 3525 |
| 3/4 | 230 | 180 | 285 | 455 | 720 | 1120 | 1735 | 2145 | 2620 |
| 1 | 230 | 150 | 240 | 375 | 595 | 925 | 1425 | 1775 | 2165 |
| 1 1/2 | 230 | 115 | 185 | 285 | 460 | 720 | 1120 | 1390 | 1710 |
| 2 | 230 | 90 | 150 | 235 | 370 | 580 | 915 | 1145 | 1415 |
| 3 | 230 | 70 | 115 | 180 | 280 | 450 | 715 | 895 | 1110 |
| 5 | 230 | 0 | 0 | 105 | 165 | 270 | 425 | 535 | 665 |
| 7 1/2 | 230 | 0 | 0 | 0 | 117 | 180 | 285 | 355 | 437 |

1ft = .3048 meters

ASSEMBLY

TOOLS REQUIRED FOR ASSEMBLY

- Pipe wrenches
- Pipe vises or clamps
- Teflon tape
- Gloves & safety glasses
- CSA or UL approved PVC electrical tape
- Tripod with chain hoist or some other device to support the unit while lowering it into the well
- Miscellaneous wrenches / tools as needed

INSTALLATION

BEFORE YOU INSTALL YOUR PUMP – READ THESE INSTRUCTIONS THOROUGHLY!

APPLICATION

This pump is ideal for the supply of fresh water to rural homes, farms and cabins from drilled wells. Submersible pumps are efficient, high in capacity, require very little maintenance, and are generally very economical for wells 60 feet (19 m) or more in depth.

GENERAL INFORMATION

NOTICE: The Model Number of your pump is located on the top portion of the pump shell. Record this number along with all pump installation data in the section provided on page 2, keep it in a safe place for future reference, in the event servicing is required. The most important things you should know about your well are: (1) its total depth; (2) depth to water; (3) draw down water level. (4) well capacity-GPM.

1. The well total depth is the distance from the ground level to the bottom of the well.
2. Depth to water is measured from the ground level to the water level in the well when the pump is not in operation.
3. Draw down water level is the distance from ground level to the water while water is being pumped from the well. In most wells, the water level drops when water is being pumped.
4. Well capacity is the amount of water in GPM the well produces without drawing down or water level dropping.

SUITABILITY OF WELL

IMPORTANT: The well should be fully developed by the driller. It **must** be pumped until all fine sand and foreign matter are removed **before the pump is installed**. Make sure the well is large enough to allow the pump to be set at the required depth. **Do not** set the pump below the casing perforations or well screen unless you are sure there is adequate flow of water around the motor for cooling. To determine the correct pump setting use the driller's records by taking into account the depth to water level and drawdown at the proposed pumping rate. Always keep the pump a minimum of five feet from the bottom of the drilled well.

GROUNDING

All wiring, electrical connections, and system grounding must comply with the National Electrical Code (NEC) and with any local codes and ordinances. Employ a licensed electrician.

Permanently ground all electrical components in accordance with National Electrical Code and applicable local codes and ordinances.

DO NOT ground to a gas supply line.

DO NOT connect to electric power supply until unit is permanently grounded.

If a plastic well casing is used in your installation, ground the metal well cap or well seal, providing electrical leads to the pump motor go through the well cap or well seal. Insure correct wire size is used.

Refer to local electrical code.

CABLE SPLICING METHODS

When the drop cable must be spliced or connected to the motor leads, it is necessary that the splice be water tight. The splice can be made with commercially available potting or heat shrink splicing kits. Follow the kit instructions carefully.

A) HEAT SHRINK TUBING METHOD

RECOMMENDED METHOD (KIT ORDER # 453820)

- 1) Strip about ½" of insulation from cable and lead ends.
- 2) Slide about 3" long heat shrink tubing over the cables.
- 3) Connect cable and lead ends with STA-KON or similar connectors (Figure 1).

Figure 1 Heat Shrink Splicing

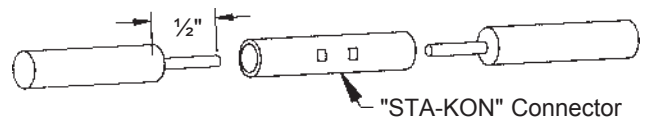

- 4) Position the tubing over the connection keeping the connector at its center.
- 5) Apply heat (about 135° C) evenly on the tubing and working from center outwards to avoid trapping air. While heated, the adhesive liner inside the tubing melts and the tubing shrinks quickly to encapsulate and insulate the connection. The adhesive liner seals the interfaces between the tubing and the connector cable. Perfect sealing is achieved when adhesive liner flows outside the tubing and seals the ends.
While heating, care must be taken not to over heat the cable outside the tubing. This will damage the insulation of the cable.

B) TAPE METHOD (alternative)

SPLICING SUBMERSIBLE CABLES WITH TAPE
Tape splicing should use the following procedure. See Figure 2.

- 1) Strip individual conductor of insulation only as far as necessary to provide room for a stake type connector. Tubular connectors of the staked type are preferred. If connector O.D. is not as large as

cable insulation, buildup with CSA/UL approved rubber electrical tape.

- 2) Tape individual joints with CSA/UL approved rubber electrical tape, using two layers; the first extending two inches beyond each end of the conductor insulation end, the second layer two inches beyond the ends of the first layer. Wrap tightly, eliminating air spaces as much as possible.
- 3) Tape over the rubber electrical tape with # 33 Scotch® or CSA/UL approved PVC electrical tape, (3M Canada Inc./Minnesota Mining and Manufacturing Co.) or equivalent, using two layers as in step "2" and making each layer overlap the end of the preceding layer by at least two inches.

In the case of a cable with **three** or **four** conductors encased in a single outer sheath, tape individual conductors as described, staggering joints. Total thickness of the tape should be no less than the thickness of the conductor insulation.

Figure 2 Tape Splicing

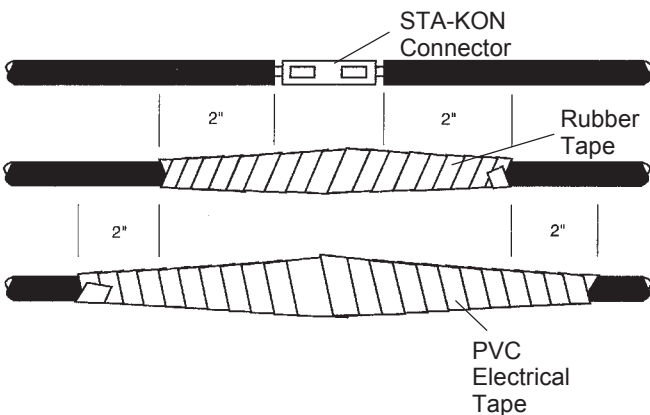

The following test is recommended before installation. Cable and splice test for leaks to ground.

- 1) Immerse the cable and splice connections into a steel barrel of water with both ends out of the water, and not touching the barrel. (figure 3)
- 2) Set ohmmeter on RX 100K and adjust needle to zero (0) with leads clipped together.
- 3) Clip one ohmmeter lead to the barrel and the other to each cable lead individually.
- 4) If the needle deflects to zero (0) on any of the cable leads a faulty splice connection is indicated. To double check the faulty splice connection, pull the splice out of the water. If the needle now moves to ∞ (infinite resistance) the leak is in the splice.
- 5) Repairs should be made with CSA and or UL approved electrical Rubber & PVC tape.
- 6) If the leak is not in the splice, pull the cable out of the water slowly until the needle moves to ∞ . When the needle moves to ∞ the leak is at that point.

Figure 3 Cable Test

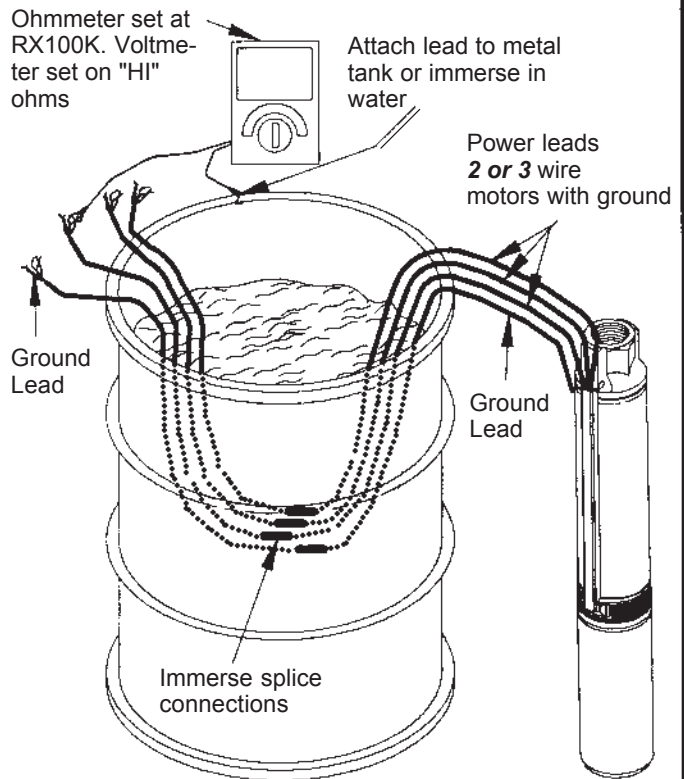

INSTALLING YOUR PUMP

PUMP LOCATION

Your submersible pump should be installed no less than 5 feet (1.5 meters) from the bottom of your well.

CAUTION: To avoid accidental loss of the pump in the well, it is recommended that a 1/4" polypropylene rope be permanently attached to the eye provided on the discharge head of the pump. The other end of the polypropylene rope should be secured to an anchor at the well head.

DRILLED WELL INSTALLATION

- 1) Check your submersible pump and accessories for physical damage.
- 2) Check the electric supply for proper voltage, fusing, wire size, grounding, and transformer size.
- 3) Check the well casing. The upper edge of the casing should be perfectly smooth. Jagged edges could cut or scrape the cable and cause a short circuit.
- 4) Select your pipe. Use only CSA approved polyethylene pipe, semi-rigid plastic pipe or schedule 40 steel pipe for setting high pressure pumps. The pipe must have sufficient strength to withstand the system's maximum pressure. The pump discharge is 1 1/4". 1" pipe may be used on the 5, 7 & 10 gpm units. On 10 gpm units when depth to water level exceeds 300 feet (91 m) deep use only 1 1/4" pipe sizes. On 15 and 20 GPM units use only 1 1/4" pipe sizes. Ensure that you have the correct length of pipe required. The pump should be installed no less than 5 feet (1.5 meters) from the bottom of the well.

INSTALLING THE PUMP WITH POLYETHYLENE PIPE

- Wrap the thread of a 1¼" NPT x 1" male plastic pipe adaptor with teflon tape if 1" pipe is being installed.
- Install the adaptor into the pump discharge opening **while holding the discharge head with a pipe wrench to prevent the head from loosening from the pump housing.**
- Install two 1" **all stainless steel** hose clamps over one end of the pipe and tighten.
- Heat the polyethylene pipe to soften the pipe.
- Press the polyethylene pipe over the adaptor.
- Tighten clamps securely around the pipe over the adaptor end.
- As the pump and pipe are lowered into the well, the submersible wire cable must be secured to the discharge pipe 5 feet from the top of the pump using electrical tape or snap wire ties. Then repeat this procedure at 10 foot (3 m) intervals along the discharge piping.

NOTE: A pipe vise or collar clamp should always be firmly affixed to the upper end of the pipe as it is being lowered.

- When the pump has reached the desired depth, pass the pipe and cable through the openings in the well seal. The discharge pipe goes through the center hole and the cable through the conduit opening. **The well seal must be vented.**
- Cut polyethylene pipe. Place two 1" clamps over the end of the pipe.
- Heat the end of the pipe to soften the pipe.
- Install a 90 degree fitting at the top of the discharge pipe.

NOTE: If the pipe was not cut, and the last section of pipe has a female connector, use a 1" x 2" long nipple and then thread the elbow into the nipple. Use teflon tape to seal joints.

- A 1" well seal elbow may be used instead of the 1" male pipe thread adaptor and elbow.
- Install the well seal into the well casing by tightening down cap screws on the well seal. **The well seal must be vented.**
- Continue pipe connection to the tank location in the house. Continue securing the submersible pump cable to the pipe. Additional clamps and fittings will be required to make the necessary connections at the elbow and at the control center.

INSTALLING THE PUMP WITH SEMI-RIGID PLASTIC PIPE

- Wrap the thread of the pipe with teflon tape.
- Thread the first section of the pipe into the pump discharge opening.
- Sections are available in 10 and 20 foot lengths. Use a pipe coupling and solvent to join pipe sections together.

NOTE: A pipe vise or collar clamp should always be firmly affixed to the upper end of the pipe as it is being lowered.

- As the pipe is lowered, the submersible wire cable must be secured to the discharge pipe 5 feet from the top of the pump using electrical tape. Then repeat this procedure at 10 foot (3 m) intervals along the discharge piping.
- When the pump has reached the desired depth, pass the pipe and cable through the openings in the well seal. The discharge pipe goes through the centre hole and the cable through the conduit opening. The well seal must be vented.
- Cut the last section to the length required.
- Install a 1" or 1¼" male connector over the end of the pipe using solvent to weld the pieces together.
- Wrap the threads of a 90 degree plastic elbow with teflon tape.
- Thread the elbow into the male connector.

NOTE: If the pipe was not cut, and the last section of pipe has a female connector, use a 2" long nipple and then thread the elbow into the nipple.

- Install the well seal into the well casing by tightening down cap screws on the well seal. **The well seal must be vented.**
- Continue pipe connection to the tank location in the house. Continue securing the submersible pump cable to the pipe. Additional clamps and fittings will be required to make the necessary connections at the elbow and at the control center.

INSTALLING THE CONTROL CENTER

(Figure 5)

Note: Teflon tape must be used on all thread joints.

- Wrap the outside thread of the tank control centre with teflon tape at position (A) and thread into tank opening (see fig. 4). Control center will thread directly into 1" opening in the side of the pre-charged tank.
- Install the pressure gauge with a 3/4" x 1/4" bushing at the opening marked position (B) on the control centre.
- Install A pressure switch or "loss of pressure" switch using 1/4" x 3" nipple at the opening position (C) in the control centre.
- Connect pipe coming from well and pump to position (E) in the control center using the appropriate male plastic pipe adapter and clamp, if polyethylene is used, or thread directly into control center if ABS or steel pipe is used.
- Proceed from position (D) on the control centre to house service lines.

NOTE: The use of teflon tape is recommended on all threaded joints.

NOTE: It is recommended that the 1 HP and 1 1/2 HP models should not be installed where the pumping level is less than 30 m (100 ft.).

Figure 4 Tank Openings

"Captive Air"
Precharged Tank

Epoxy or Glass Lined
Prechargeable Tank

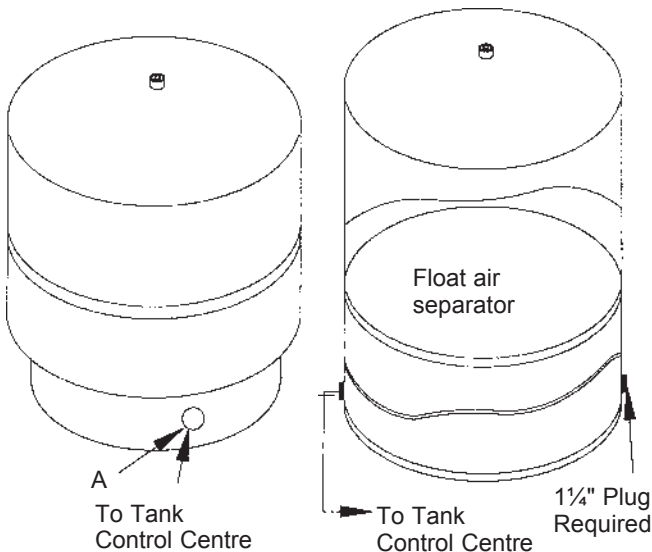
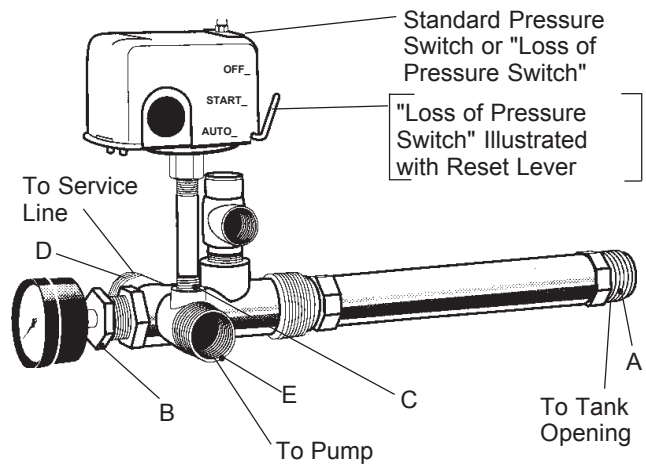

Figure 5 The Control Center



LAKE OR LARGE DIAMETER WELL INSTALLATION

All wiring, electrical connections and system grounding must comply with the National Electrical Code (NEC) and with any local codes and ordinances. Employ a licensed electrician.

If a pump is installed in a lake or large diameter well, a flow inducer sleeve must be placed around the motor. The sleeve should have an inside diameter of 4" to 6", and be composed of corrosion resistant metal or heavy plastic. The sleeve will ensure proper flow of water around the motor for cooling purposes. The flow inducer sleeve is closed off above the pump intake and extends to the bottom of the motor or lower as shown in Figure 6.

Figure 6 Flow Inducer Sleeve

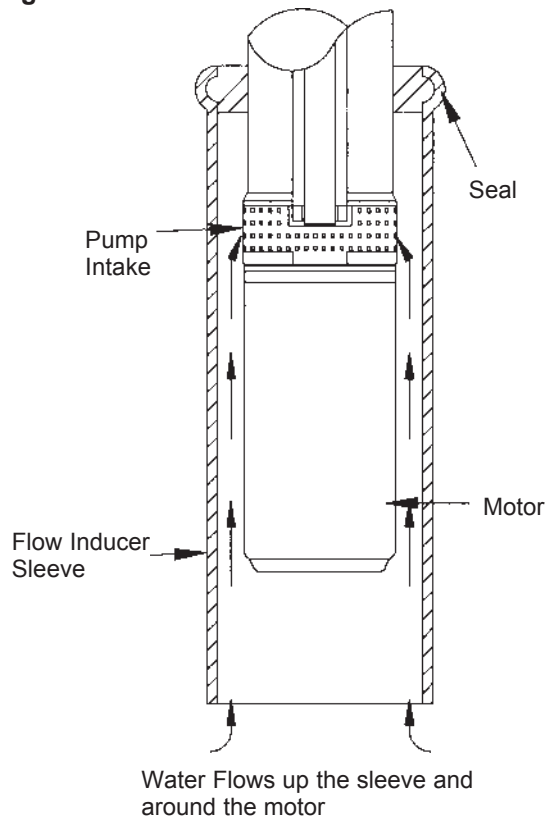
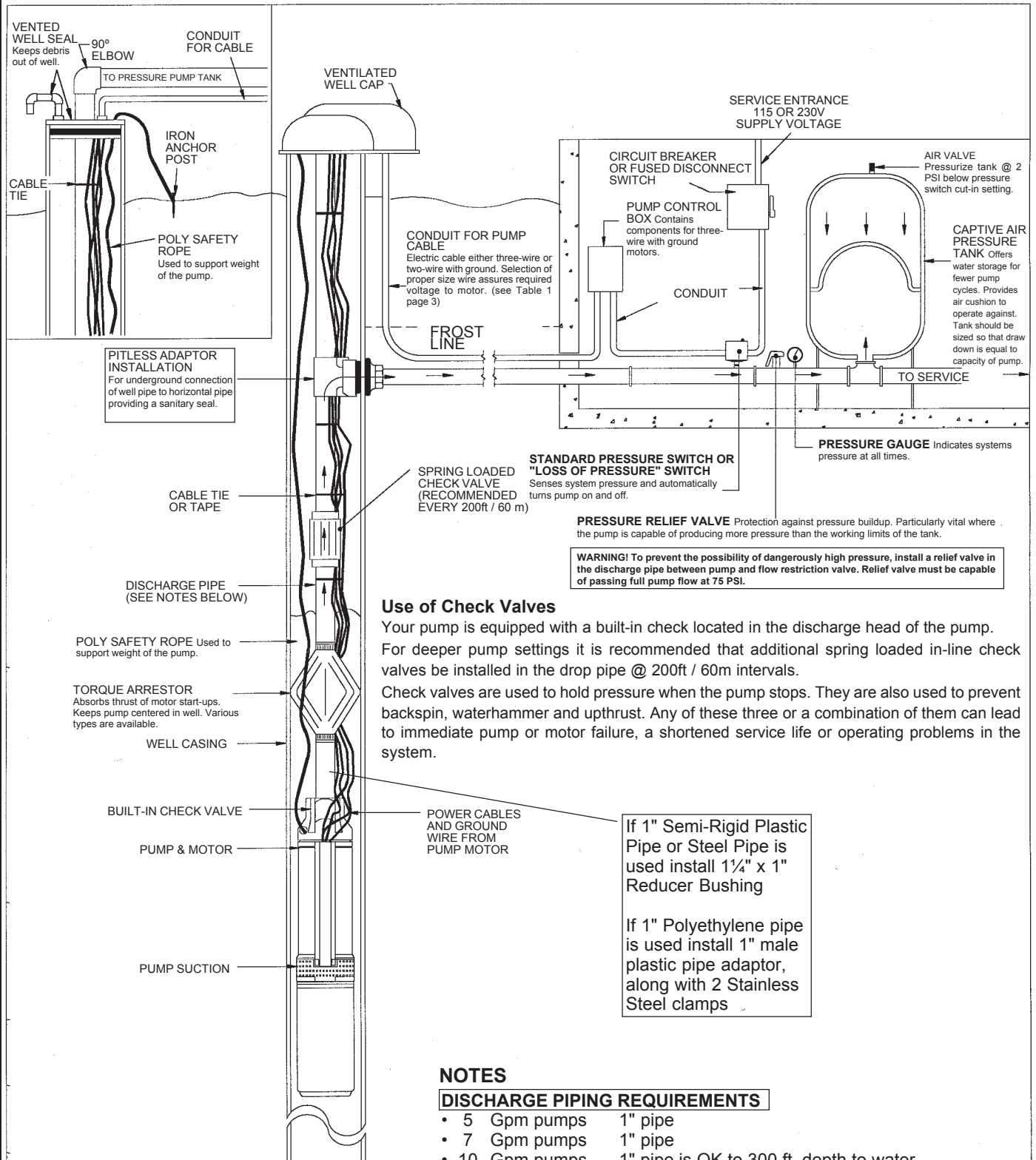

Figure 7 Pump Installation

**PICTORIAL OF 3 WIRE SYSTEM WITH AND WITHOUT A PITLESS ADAPTOR
(SEE PAGE 10 FIG. 9 IN THIS MANUAL FOR WIRING DIAGRAMS)**

INSTALLATION



WARNING! To prevent the possibility of dangerously high pressure, install a relief valve in the discharge pipe between pump and flow restriction valve. Relief valve must be capable of passing full pump flow at 75 PSI.

Use of Check Valves

Your pump is equipped with a built-in check located in the discharge head of the pump. For deeper pump settings it is recommended that additional spring loaded in-line check valves be installed in the drop pipe @ 200ft / 60m intervals. Check valves are used to hold pressure when the pump stops. They are also used to prevent backspin, waterhammer and upthrust. Any of these three or a combination of them can lead to immediate pump or motor failure, a shortened service life or operating problems in the system.

If 1" Semi-Rigid Plastic Pipe or Steel Pipe is used install 1¼" x 1" Reducer Bushing

If 1" Polyethylene pipe is used install 1" male plastic pipe adaptor, along with 2 Stainless Steel clamps

NOTES

DISCHARGE PIPING REQUIREMENTS

- 5 Gpm pumps 1" pipe
- 7 Gpm pumps 1" pipe
- 10 Gpm pumps 1" pipe is OK to 300 ft. depth to water
- 10 Gpm pumps 1¼" pipe if the depth to water exceeds 300 ft.
- 15 Gpm pumps 1¼" pipe
- 20 Gpm pumps 1¼" pipe

Figure 8 Pump Installation

**PICTORIAL OF 2 WIRE SYSTEM WITH AND WITHOUT A PITLESS ADAPTOR
(SEE PAGE 10 FIG. 9 IN THIS MANUAL FOR WIRING DIAGRAMS)**

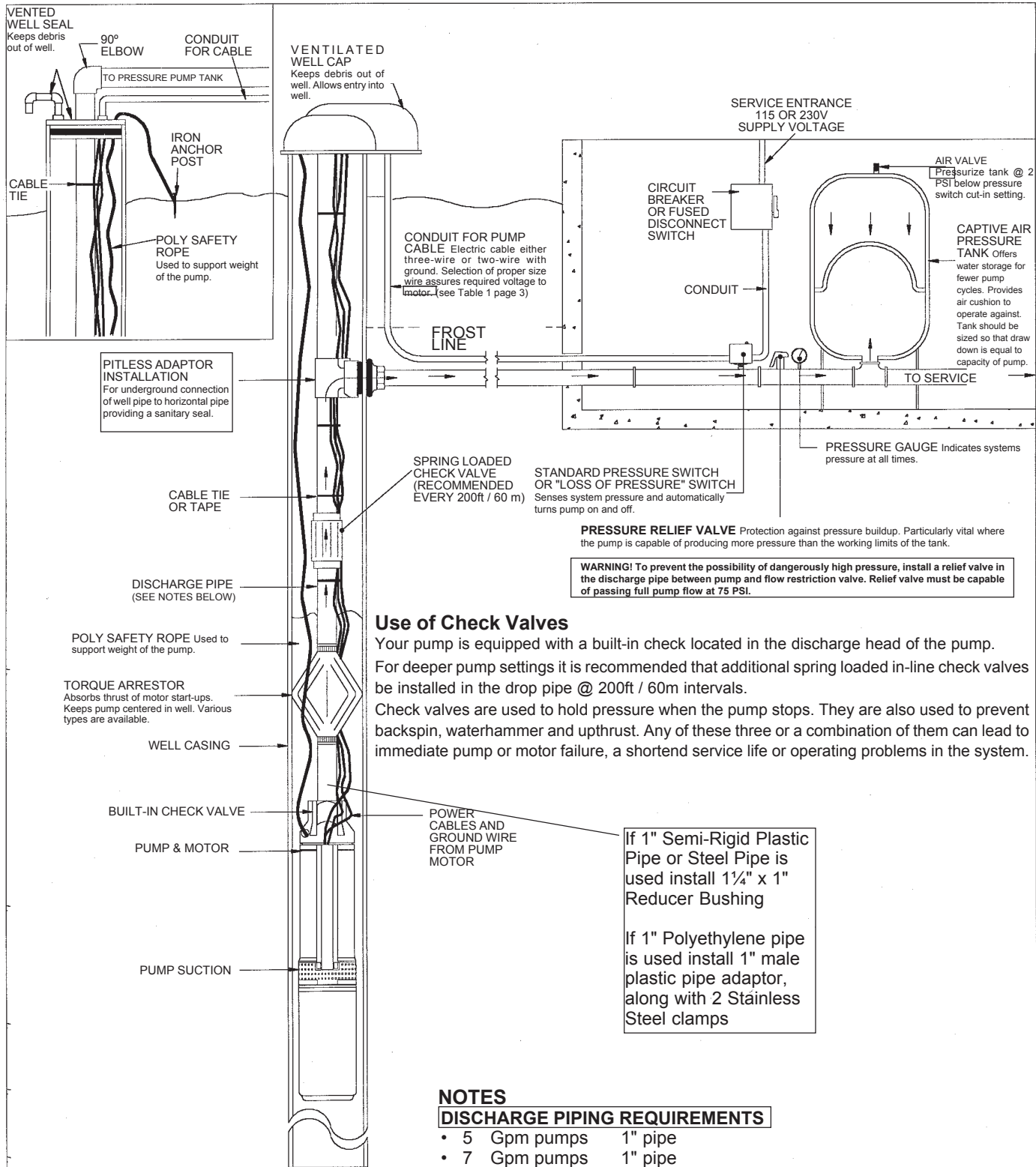

INSTALLATION

Use of Check Valves

Your pump is equipped with a built-in check located in the discharge head of the pump. For deeper pump settings it is recommended that additional spring loaded in-line check valves be installed in the drop pipe @ 200ft / 60m intervals. Check valves are used to hold pressure when the pump stops. They are also used to prevent backspin, waterhammer and upthrust. Any of these three or a combination of them can lead to immediate pump or motor failure, a shortened service life or operating problems in the system.

If 1" Semi-Rigid Plastic Pipe or Steel Pipe is used install 1 1/4" x 1" Reducer Bushing

If 1" Polyethylene pipe is used install 1" male plastic pipe adaptor, along with 2 Stainless Steel clamps

NOTES

DISCHARGE PIPING REQUIREMENTS

- 5 Gpm pumps 1" pipe
- 7 Gpm pumps 1" pipe
- 10 Gpm pumps 1" pipe is OK to 300 ft. depth to water
- 10 Gpm pumps 1 1/4" pipe if the depth to water exceeds 300 ft.
- 15 Gpm pumps 1 1/4" pipe
- 20 Gpm pumps 1 1/4" pipe

ELECTRICAL CONNECTIONS

(Figure 9)

WARNING – Electrical precautions

ALL WIRING, ELECTRICAL CONNECTIONS AND SYSTEM GROUNDING MUST COMPLY WITH THE NATIONAL ELECTRICAL CODE (NEC) AND WITH ANY LOCAL CODES AND ORDINANCES. A LICENSED ELECTRICIAN SHOULD BE EMPLOYED.

WARNING . . . Risk of Electrical Shock

Employ a licensed electrician to do the electrical wiring. A separate circuit breaker in your home's electrical panel is required. A ground fault interrupter (GFI) protected circuit should be used for all electrical devices operating near water. Install a properly fused disconnect switch in the line and make certain the wiring is adequately sized and well insulated. **Undersized wire between the motor and the power source will adversely limit the starting and load carrying abilities of the motor and void warranty.** Minimum wire sizes for motor branch circuits are recommended in Table 1, Page 3. **For safety, the pump motor must be properly grounded.** For fusing requirements see Table 2.

- ❑ Turn off main power supply to pump before attempting in wiring
- ❑ Turn the pressure switch control lever to the "OFF" position, (if your switch is equipped with a control lever) disconnecting the switch.
- ❑ Remove the cover from the pressure switch by loosening the cover nut. Connect the wires coming from the power source to the "LINE" terminals on the pressure switch. **Use no less than 14 gauge wire to the terminals on the pressure switch.**
- ❑ Cut the submersible wire cable to length from the well and connect the wires to the "LOAD" terminals on the pressure switch.
- ❑ Replace the cover on the pressure switch and re-set lever to **AUTO** if your switch is so equipped.

Table 2 - Circuit Breaker or Fuse Requirements (SINGLE PHASES 2 AND 3 WIRE FRANKLIN MOTORS)

| Motor Horsepower | Number of wires | Voltage supply | Breaker or fuse size | |
|------------------|-----------------|----------------|----------------------|-------|
| | | | standard | delay |
| 1/3 HP | 2 or 3 wire | 115 | 25 | 10 |
| | | 230 | 15 | 5 |
| 1/2 HP | 2 or 3 wire | 115 | 30 | 15 |
| | | 230 | 15 | 7 |
| 3/4 HP | 2 or 3 wire | 230 | 20 | 9 |
| 1 HP | 2 or 3 wire | 230 | 25 | 12 |
| 1-1/2 HP | 2 wire | 230 | 35 | 15 |
| 1-1/2 HP | 3 wire | 230 | 30 | 15 |
| 2 HP | 3 wire | 230 | 30 | 15 |
| 3 HP | 3 wire | 230 | 45 | 20 |
| 5 HP | 3 wire | 230 | 70 | 30 |

STARTING THE PUMP

Turn the circuit breaker switch to the "ON" position to start pump. Pump should start building pressure immediately. Allow pump to run until water runs clear.

NOTE: If your pressure switch is equipped with a loss of pressure cut-off switch (with a lever) it will be necessary for you to hold the lever in the start position until the pump builds sufficient pressure to remain on without holding lever in the start position. The pump will run until system pressure builds up to the cutoff setting of the switch. The system will operate automatically between the cut-in & cut-out pressure settings on the switch.

Figure 9 Wiring Diagram

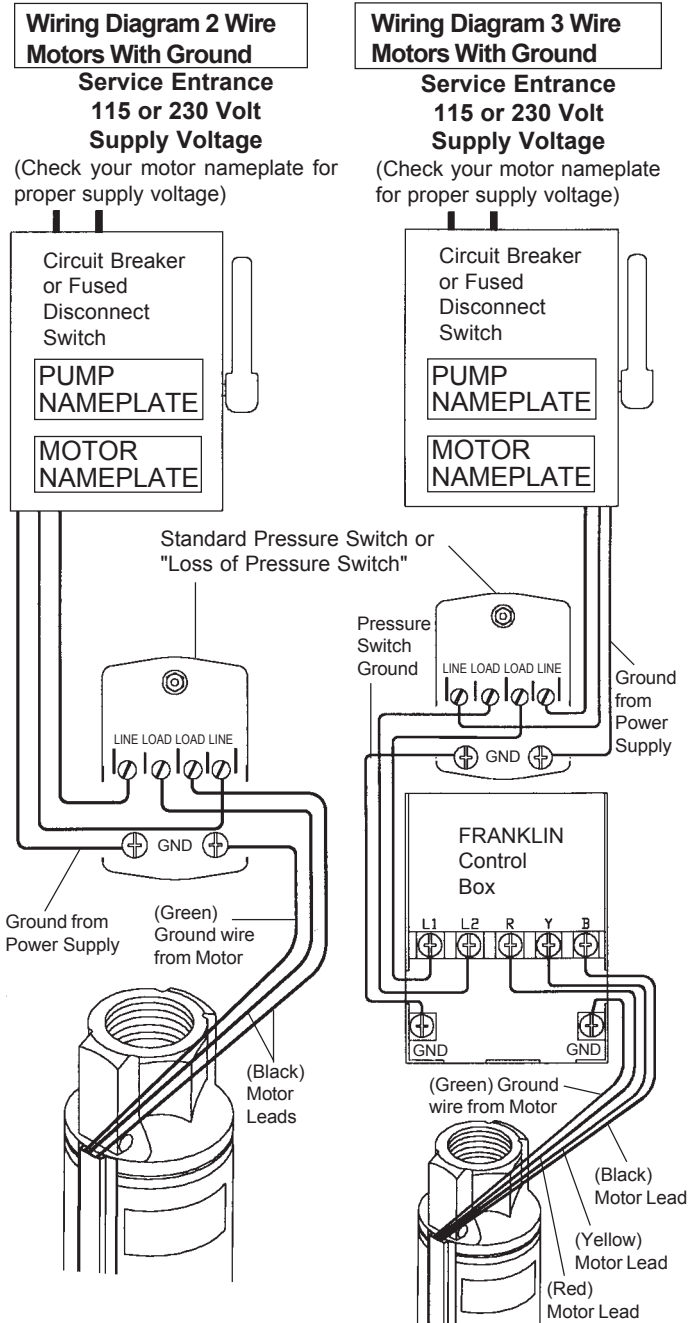

MAINTENANCE

No regular maintenance is required on a submersible pump. However, it is advisable to check the wiring and piping annually.

TROUBLE SHOOTING

| TROUBLE | CAUSES | CORRECTIVE ACTION |
|--|--|---|
| <p>Your pump delivers little or no water</p> | <ol style="list-style-type: none"> 1. Water level in a low producing well drops too low while pump is operating, causing it to air lock. (Resulting in loss of prime and possibly serious damage to the pump) 2. Intake screen is partially plugged. 3. Check valve(s) may be stuck. 4. Voltage is too low; the motor runs slowly, causing low discharge pressure (head) and high operating current draw. | <ol style="list-style-type: none"> 1. Lower the pump further into the well, but make sure it is at least five feet from the bottom of the well. Install a control valve in the discharge pipe between the pump and pressure tank. Use the control valve to restrict the flow until the discharge rate does not exceed well recovery rate. WARNING! To prevent the possibility of dangerously high pressure, install a relief valve in the discharge pipe between pump and flow restriction valve. Relief valve must be capable of passing full pump flow at 75 PSI. 2. Lime or other matter in the water may build up on screen. Pull pump and clean screen. 3. Make sure that the built-in check valve in the pump and any check valves in the discharge line are free to open properly. 4. Have a certified electrician verify voltage at the electrical disconnect box (2 wire) or control center (3 wire) while the pump is operating. If the voltage is low, the power company may need to raise it or installation may require larger wire. Discuss this with the power company or a licensed electrician. |
| <p>Air or milky water discharges from your faucets</p> | <ol style="list-style-type: none"> 1. Well water may be gaseous. | <ol style="list-style-type: none"> 1. If your well is naturally gaseous and your system has a standard tank, remove the bleeder orifices and plug the tees. If the condition is serious, check with certified well professionals. |
| <p>Pump starts too frequently</p> | <ol style="list-style-type: none"> 1. Leak in the pressure tank or plumbing. 2. Pressure switch is defective or out of adjustment. 3. Check valve is leaking. 4. Tank is waterlogged. 5. Drop pipe leaking. 6. Pressure switch is too far from the tank. | <ol style="list-style-type: none"> 1. Check all connections with soapsuds for air leaks. Fix any leaks you find. Check the plumbing for water leaks. Fix any leaks you find. 2. If necessary, replace switch. 3. Inspect valves and replace if necessary. 4. Captive Air® Tanks: Check the tank for leaks; correct if possible. Precharge tanks to 18 PSI with a 20-40 PSI switch, 28 PSI for a 30-50 PSI switch, 38 PSI for a 40-60 PSI switch, etc. Standard tanks: Check the tank for leaks; correct if possible. Check bleeder orifices and clean bleeders; replace if necessary. 5. Raise one length of pipe at a time until the leak is found. When water stands in the pipe there is no leak below this point. 6. Move the pressure switch to within one foot of the tank. |
| <p>Fuses blow or overload protector trips when the motor starts</p> | <ol style="list-style-type: none"> 1. Fuses or wires are too small. 2. Low or high voltage. 3. Cable splices or motor windings grounded, shortened, or open. 4. 3-wire only; Cable leads may be improperly connected in pump control box, pressure switch or fused disconnect switch. 5. 3-wire only; there may be a broken wire in the pump control box. 6. 3-wire only; Starting or running capacitor in control box may be defective or vented (blown out). | <ol style="list-style-type: none"> 1. Replace with correct wire sizes (see Table 1 on page 3). 2. While motor is running, voltage should not exceed plus 5% or minus 5% or rated voltage shown on motor nameplate. Call the electric power company to adjust line voltage if not within these limits. 3. Consult certified electrician or service technician. 4. Check wiring diagram on pump control box (also see Figure 9 on page 10) and color coding of drop cable. 5. Employ certified electrician examine all connections and wiring in control panel. If necessary, repair them. 6. Inspect capacitors. Employ a certified electrician to check capacitors & replace them if necessary. <p>WARNING! hazardous voltage, can shock, burn, or cause death. Capacitors may still carry voltage charges even after being disconnected from wiring. Have them checked by a certified electrician.</p> |

TROUBLE SHOOTING

TROUBLE SHOOTING

| TROUBLE | CAUSES | CORRECTIVE ACTION |
|--|--|--|
| <p>Motor will not start but does not blow fuses.</p> <div style="border: 1px solid black; padding: 5px; margin-top: 10px;"> <p>WARNING! Hazardous voltage. Can shock, burn, or cause death. Employ a qualified electricians should work on electrical service.</p> </div> | <ol style="list-style-type: none"> 1. No voltage to motor. 2. Cable splices or motor windings may be grounded, shorted, or open-circuited. 3. Open circuit in pump control box (3-wire only); faulty connections; faulty wires. 4. Faulty pressure switch. 5. 3-wire only; Cable leads improperly connected in the control center. | <ol style="list-style-type: none"> 1. With a voltmeter check; 1) fuse box to make sure full voltage is available; 2) pressure switch terminals, to make sure pressure switch is passing voltage correctly; and 3) terminal strips in pump control box or disconnect switch box to make sure voltage is available there. On 1 ½ through 3 HP: Push red overload reset button(s) on the bottom of control center. 2. Consult certified electrician or service technician. Do not attempt to disassemble pump or motor. 3. Examine all connections and wires; examine terminal strips in the control center (3-wire only); repair if necessary. 4. Check pressure switch; replace if necessary. 5. Check wiring diagram on control center panel (or see Figure 9 on page 10 of this manual) and color coding of drop cable. |
| <p>Pressure switch fails to shut off pump.</p> | <ol style="list-style-type: none"> 1. Voltage is too low; motor will run slowly, causing low discharge pressure (head) and high operating current draw. 2. Faulty pressure switch. 3. Drop pipe is leaking. 4. Water level in the well may become too low when pump is running. | <ol style="list-style-type: none"> 1. Have a certified electrician verify voltage at the electrical disconnect box (2-wire) or the pump control box (3-wire) while the pump is operating. If the voltage is low, your power company may need to raise it or installation may require larger wire. Discuss with the power company or a certified electrician. Check voltage with a recording meter if trouble reoccurs. 2. Replace switch. 3. Raise one length at a time until the leak is found. When water stands in the pipe, there is no leak below this point. 4. Lower pump further into well, make sure it is between five and ten feet from the bottom of the well. Install a valve into the discharge pipe between the pump and the pressure tank. Use the valve to restrict flow until discharge rate does not exceed the well recovery rate. <div style="border: 1px solid black; padding: 5px; margin-top: 10px;"> <p>WARNING! To prevent the possibility of dangerous high pressure, install a relief valve in the discharge pipe between the pump and flow restriction valve. The relief valve must be capable of passing full pump flow at 75 PSI.</p> </div> |
| <p>Fuses blow or overload protector trips when motor is running.</p> | <ol style="list-style-type: none"> 1. Low or high voltage. 2. 3-Wire only: High ambient (atmospheric) temperature. 3. 3-Wire only: pump Control box wrong horsepower or voltage for installation. 4. Wire size is too small. Improperly connected in the pump control box. 5. Cable splices or motor windings may be grounded, shorted or open-circuited. | <ol style="list-style-type: none"> 1. While the motor is running, voltage should not exceed plus 5% or minus 5% of rated voltage shown on motor nameplate. Call your power company to adjust line voltage if it is not within these limits. 2. Make sure the pump control box is installed out of direct sunlight. 3. Compare horsepower and voltage rating of motor (from motor nameplate) with those of the pump control box (from pump control box nameplate). These numbers must match. 4. See Table 1 on page 3 of this manual and make sure the wire sizes match specifications in the Table. 5. Consult certified electrician or a service technician to determine if this is the cause of the problem or not. Do not attempt to disassemble pump or motor. |

MONARCH INDUSTRIES
51 Burmac Road, P.O. Box 429
Winnipeg, Manitoba, Canada
R3C 3E4

Phone: (204) 786-7921
Fax: (204) 889-9120

www.monarchindustries.com

MONARCH INDUSTRIES