



WATER SYSTEMS SHALLOW WELL JET PUMPS

Water Systems

Sump & Sewage

Lawn & Sprinkler

Electric Motor Driven

Engine Driven

Frame Mount

Hand Pumps

Irrigation & Industrial

MJS SERIES SHALLOW WELL JET PUMPS

Pump - motor assembly with internal injector and 30-50 PSI pressure switch and pressure gauge. All pumps have 1 1/4" NPT suction and 1" NPT discharge. Model MJSHP-50 is recommended for 40-60 PSI pressure setting.

Ideal for supplying pressurized freshwater to rural homes, farms and cabins. For use where the vertical distance from the water supply does not exceed 25 feet.

- Cast Iron casing and seal plate ensures durability and long life.
- Precision engineered thermoplastic impeller, diffuser, nozzle and venturi.
- A.O. Smith **higher than standard Nema service factor** dual compartment motors.
- Dual voltage (115/230) Stainless Steel Motor Shaft, Dual Ball Bearing.
- Square D pressure switch preset at 30-50 PSI for today's modern living conditions.
- John Crane type 6 mechanical seal ensures years of leak free operation.
- Fully serviceable with two year over the counter warranty.
- Clean out plug to easily unclog nozzle.
- Pressure gauge included on all models.



Dual compartment A.O. Smith motor



MJS-50

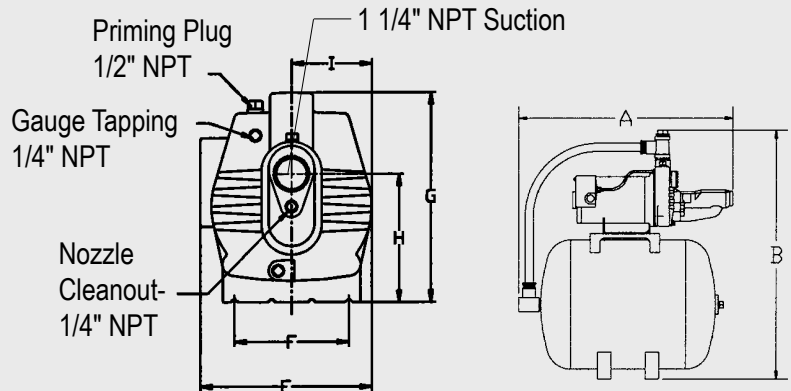
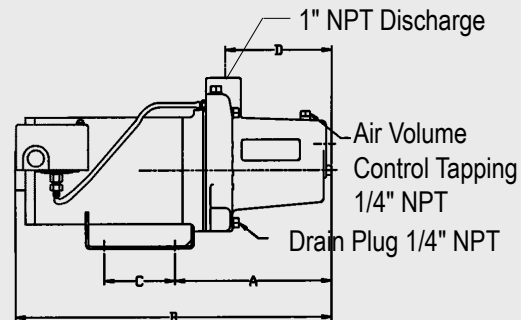

Model	Suct.	Disch.	A	B	C	D	E	F	G	H	I	Ship Wt. (lbs)
MJS-50	1 1/4"	1" NPT	9.38	17.3	3	6	9	4.85	9.8	4.62	3.5	36
MJS-75	1 1/4"	1" NPT	9.38	17.3	3	6	9	4.85	9.8	4.62	3.5	37
MJS-100	1 1/4"	1" NPT	9.38	17.3	3	6	9	4.85	9.8	4.62	3.5	38
MJSHP-50	1 1/4"	1" NPT	9.38	17.3	3	6	9	4.85	9.8	4.62	3.5	36

*Dimensions measured in inches

Model	HP	Tank (Gal.)	Length	Width	Height	Ship Wt. (lbs)
MJS-50/PC15S	1/2	4.5	23"	12"	27"	54
MJS-50/PC25S	1/2	8.5	25"	13"	29"	57

WATER SYSTEMS SHALLOW WELL JET PUMPS

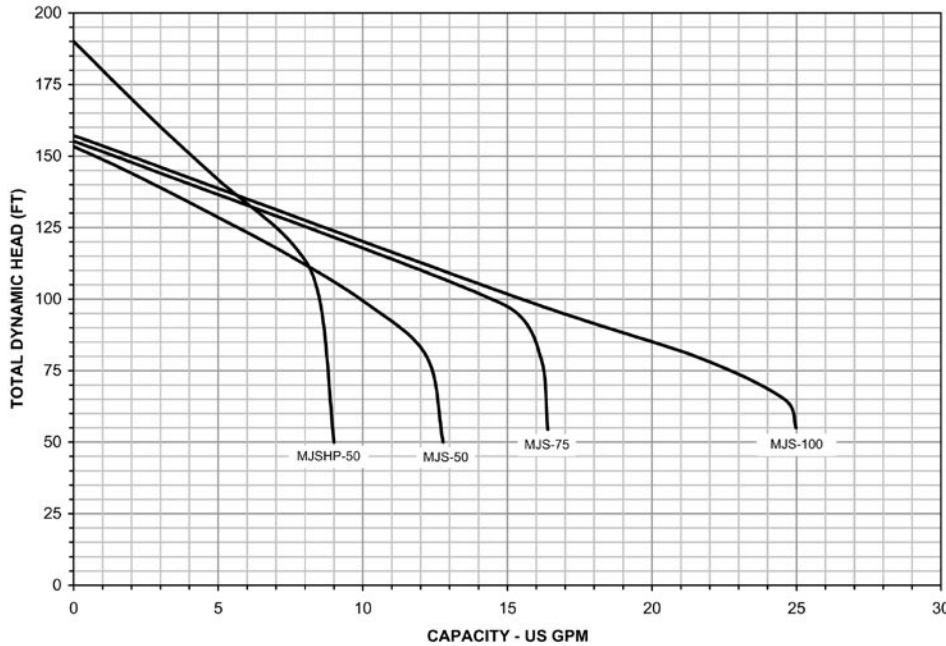

MJS-50/PC25S

Performance Table

Pump Model	Motor HP	Total Suction Lift (ft.)	Pump Capacity in U.S. GPM													Maximum Pressure
			Discharge Pressure in PSI													
			20	25	30	35	40	45	50	55	60	65	70	75	80	
MJS-50	1/2	5	12.8	12.5	12.3	12.1	11.2	9.5	6.9	4.3	2.0	-	-	-	-	64.2
		10	11.5	11.3	11.0	10.8	10.4	8.5	6.0	3.4	1.0	-	-	-	-	62.0
		15	9.8	9.7	9.6	9.5	9.4	7.3	4.7	2.2	-	-	-	-	-	59.9
		20	8.3	8.1	7.8	7.7	7.6	5.7	3.5	1.0	-	-	-	-	-	57.7
		25	5.6	5.55	5.5	5.4	5.3	4.1	2.3	0.2	-	-	-	-	-	55.5
MJS-75	3/4	5	16.2	16.0	15.8	15.6	15.4	12.1	8.7	5.7	2.9	-	-	-	-	65.0
		10	14.3	14.0	13.7	13.5	13.2	10.6	7.6	4.6	1.6	-	-	-	-	62.8
		15	12.1	11.7	11.3	11.0	10.6	9.3	6.3	3.2	0.2	-	-	-	-	60.6
		20	9.9	9.6	9.3	9.0	8.7	7.8	4.8	1.9	-	-	-	-	-	58.5
		25	7.2	7.1	7.0	6.9	6.8	6.7	3.5	0.6	-	-	-	-	-	56.3
MJS-100	1	5	24.8	24.7	23.2	19.8	16.5	13.1	9.5	6.3	3.4	0.5	-	-	-	66.2
		10	21.5	21.2	20.1	18.4	15.2	11.5	7.9	4.9	2.4	-	-	-	-	64.2
		15	18.1	17.8	17.4	16.7	13.8	10.3	6.9	4.0	1.3	-	-	-	-	62.1
		20	14.4	14.3	14.2	14.6	12.3	9.0	5.3	2.3	0.2	-	-	-	-	60.1
		25	10.5	10.5	10.4	10.3	8.8	7.0	4.2	1.3	-	-	-	-	-	57.2
MJS HP-50 High Pressure	1/2	5	8.8	8.9	8.6	8.4	8.3	8.1	7.4	6.0	4.7	3.4	2.2	1.2	0.15	80.6
		10	7.8	7.7	7.55	7.4	7.25	7.2	6.6	5.4	4.15	2.8	1.8	0.7	-	78.5
		15	6.5	6.4	6.3	6.2	6.1	6.0	5.3	4.8	3.6	2.3	1.3	0.3	-	76.3
		20	5.3	5.2	5.1	4.9	4.8	4.7	4.6	4.1	2.9	1.7	0.7	-	-	74.1
		25	3.7	3.65	3.6	3.55	3.5	3.5	3.5	3.45	2.4	2.3	1.3	0.3	-	71.9

MJS SERIES - FOR SHALLOW WELLS TO 25 FEET

Model	Order #	HP	SF	Voltage	Ship Wt. (lbs.)	Description
MJS-50	602002	1/2	1.90	115/230	36	1/2 HP Shallow well jet pump
MJS-75	602003	3/4	1.65	115/230	37	3/4 HP Shallow well jet pump
MJS-100	602004	1	1.65	115/230	39	1 HP Shallow well jet pump
MJSHP-50	602011	1/2	1.90	115/230	36	1/2 HP High Pressure Shallow well jet
SHALLOW WELL JET PUMP AND TANK PACKAGED SYSTEMS						
MJS-50/PC15S	602012	1/2	1.90	115/230	54	Jet pump with 4.5 gallon Flexcon tank
MJS-50/PC25S	602013	1/2	1.90	115/230	64	Jet pump with 8.5 gallon Flexcon tank

Water Systems

Sump & Sewage
Lawr & Sprinkler

Electric Motor
Driven

Engine Driven

Frame Mount

Hand Pumps

Irrigation &
Industrial