



SUMP & SEWAGE SUMP/EFFLUENT PUMPS

ESP50 SERIES

SUBMERSIBLE EFFLUENT PUMP

SOLIDS HANDLING CAPABILITY - 3/4"

CONSTRUCTION - Rugged cast iron motor housing dissipates heat away from motor. Rugged corrosion resistant, molded polypropylene pump body.

MOTOR - 115 volt thermal overload protected, CSA approved continuous duty "oil free" motor. Stainless steel heat treated shaft. Carbon/Ceramic mechanical seal. Upper and lower ball bearings. 6.9 full load amps.

IMPELLER - Reinforced polypropylene, handles 3/4" spherical solids - with brass insert.

SWITCH - Automatic with mercury free mechanical float switch or vertical float switch. Also available in manual operation.

POWER CORD - 20 ft. power cord.

DISCHARGE - 1 1/2" NPT.



ESP50AV

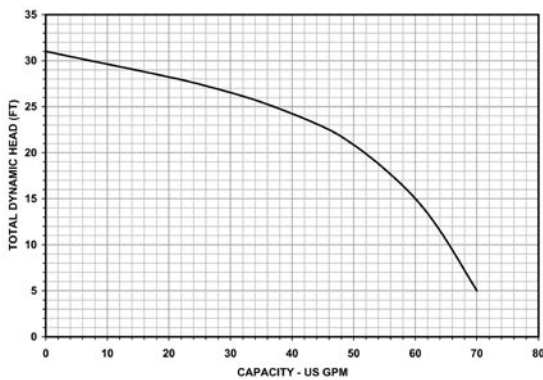

Performance Chart

Model No.	Total Head in Feet					Shut-Off Head (ft.)	
	5	10	15	20	25		30
Capacities in U.S. GPM							
ESP50	-	-	61	51	36	2	31

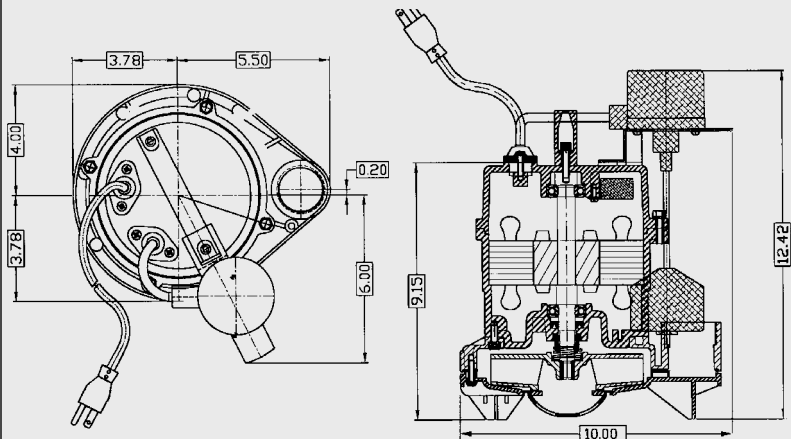

Submersible Sump/Effluent Pumps - 1 1/2"

Model No.	Order No.	HP	Ship Wt. (lbs.)	Description
ESP50A	620176	1/2	24	Automatic, with integral float switch and 20 ft. cord.
ESP50AV	620178	1/2	24	Automatic, with vertical float switch, 20ft cord.
ESP50M	620174	1/2	24	Manual, with 20 ft. power cord.

Water Systems

Sump & Sewage

Lawn & Sprinkler

Electric Motor Driven

Engine Driven

Frame Mount

Hand Pumps

Irrigation & Industrial